

FITTING INSTRUCTIONS

ATTENTION: before carrying out any work on the exhaust, check that its surface has cooled so that it will not damage components, which are not heat-resistant (such as fairing, hoses, rubber sleeves, etc.), or the operator.

- 1.** Completely loosen the original nuts and bolts that secure the original manifold to the cylinder (through a flange) and the silencer to the frame, and then remove the original exhaust system.
- 2.** Insert the manifold into the cylinder head attachment; locate the flange by fitting it to the studs; avoid tightening the original nuts completely in order to ensure correct positioning and to take advantage of the play existing between the flange and the stud bolts.
- 3.** Insert the silencer into the manifold; check its correct position and secure it with the spring supplied.
- 4.** Fit the strap/s to the silencer (and the rubber shoe/s when present) and secure them to the frame of the bike with the supplied findings (see enclosed drawing).
- 5.** (Secure the manifold to the bike frame).
- 6.** Check the correct positioning of all of the assembled parts and then tighten details completely.
- 7.** Start up the engine; wait a few minutes until the running temperature is reached and then check that there is no gas leakage.

IMPORTANT: During the first km of running, the exhaust system needs breaking-in; therefore, slight gas leakage might occur.

ADJUSTMENT:

This silencer has been developed by Leovince on an electronic test bed using a machine in perfect condition, and in standard trim. To obtain best results, we would suggest that you check the carburation of your machine in function of its state and condition, and the climatic conditions in your region.

MAINTENANCE:

From time to time, check all the brackets and fasteners, which could be affected by use (sound-deadening material, seals and other rubber parts) and replace them periodically. The silencer may be cleaned using gasoline, diesel oil or alcohol. Absolutely avoid the use of any kind of solvent. It is normal for there to be some discolouration of the silencer, which is the result of heat and the nature of the materials used.

IT IS FORBIDDEN to modify silencers. Whatever form this may take, SITO GRUPPO INDUSTRIALE declines any responsibility for defects, problems, or malfunction, arising from the use of any product which has been modified or tampered with.

WE SUGGEST THE FITTING TO BE MADE BY PROFESSIONALS

TECHNICAL DRAWING

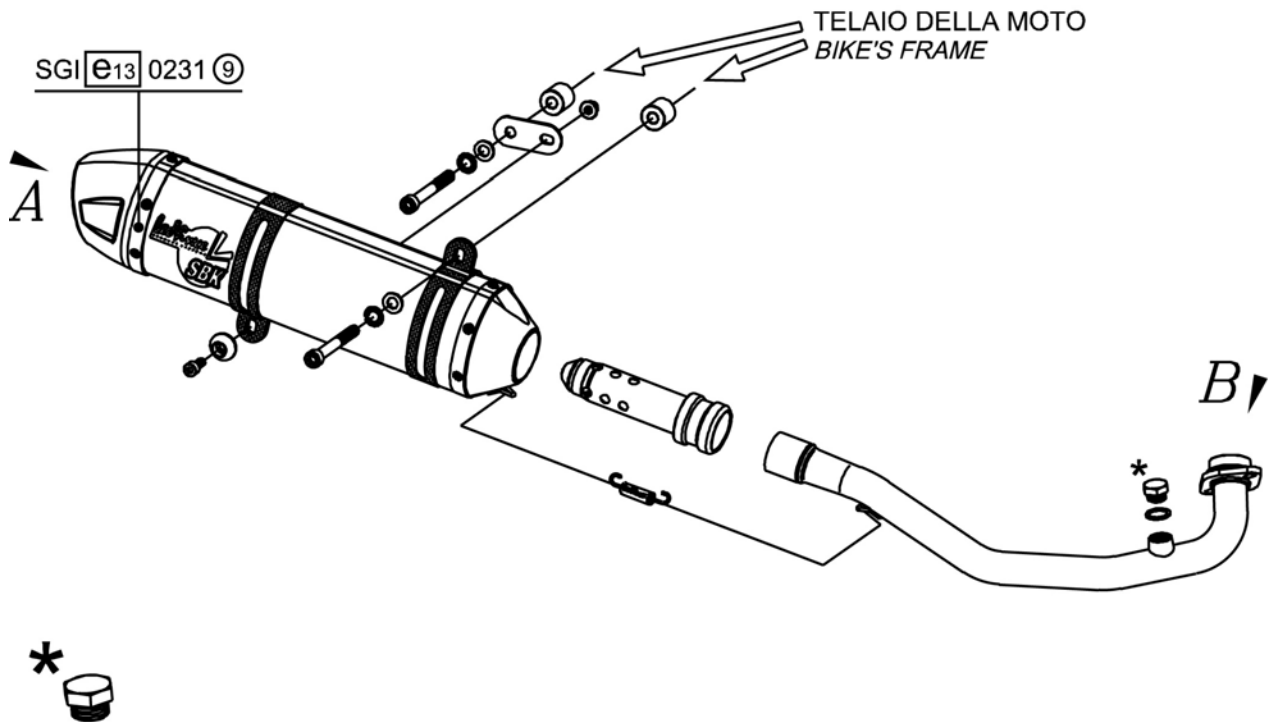
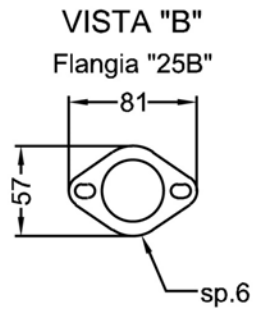
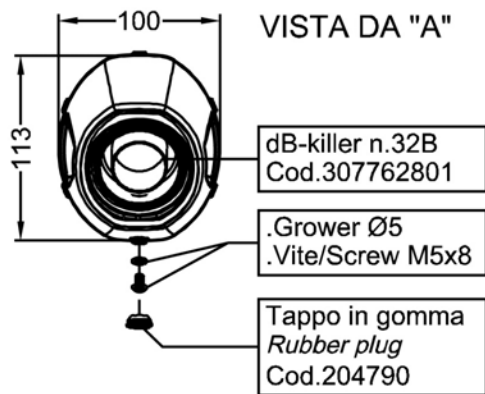

- I)** Componenti forniti in confezione e da utilizzare solo sulle motociclette non dotate di sonda Lambda: .Guarnizione + Tappo M18x1,5 h.9
- GB)** By-packed components to be used only on motorcycles not provided with Lambda probe: .Seal + Plug M18x1,5 h.9
- F)** Pièces fournies et à utiliser seulement sur les motocycles qui ne sont pas équipés de sonde Lambda: .Garniture + Bouchon M18x1,5 h.9
- D)** Mitgelieferte Bauteile, die nur für Motorräder ohne Lambda-Sonde einzusetzen sind: .Dichtung + Stopfen M18x1,5 h.9
- E)** Componentes suministrados en confección y que hay que utilizar sólo en las motocicletas no equipadas de sonda Lambda: .Guarnición + Tapón M18x1,5 h.9

FITTING INSTRUCTIONS ROLLERS

To obtain best results from this product, we recommend you fit the VARIATOR ROLLER KIT supplied, which is designed for use on unmodified engine and transmission units.

- 1 Remove the left engine case to reach the drive unit.
- 2 Remove the centrifugal rollers from the driving half-pulley (front variator), and replace these with the kit supplied, as shown in the diagram.

Art. 5648 gr. 8,7

If all these components are changed, they will affect the performance of the machine, in the same way as the topography of the area where it is to be used, or the weight of the rider. If detailed tuning of the transmission is called for, we offer the following range of rollers of different weights:

Art. 5648 D x L (mm) 20 x 12													
gr.	6,7	7,2	7,7	8,2	8,7	9,2	9,9	10,6	11,3	12,0	12,7	13,4	14,0

Our technicians are at your disposal for further clarification and suggestions. We must remind you that tuned power units can only be used for **COMPETITION PURPOSES ON A CLOSED CIRCUIT.**

SISTEMA DI MONTAGGIO DEI RULLI HOW TO FIT ROLLERS INSTRUCTION DE MONTAGE MONTAGEANLEITUNG ISTRUCIONES DE MONTAJE

